

RESIDENTIAL LIGHTING GUIDELINES



Table of Contents

THE INTRODUCTION

- Who is Progress Lighting 3
- Sales engagement tool set 4

THE KNOWLEDGE

General Principles

How to Properly Light a Space

- Layering 7
- Wattage 8
- Lumens 8
- Efficacy 8
- Temperature 9
- Style 9
- Bulbs 10

THE DESIGN TIPS

Lighting Techniques / Sizing Guidelines

- Foyers, Hall & Stairways 14
- Dining Area 16
- Kitchen 18
- Bath & Vanity 22
- Outdoor 26
- Creative Lighting 28



A BRAND FOCUSED ON **EVERY TREND AND LIFESTYLE**

Progress Lighting is so much more than a lighting manufacturer with a rich heritage. We're illuminating a vision for the future, placing a high concentration on creating superior lighting solutions at a great value. Our brand evolution sets a fresh foundation to educate, equip and excite distributors and their customers.



WHAT MAKES OUR OFFERING UNIQUE AND DIFFERENT?

This value naturally comes in the form of our product offering, which is also paired with our unique and inspirational resources created specifically for home industry experts. We serve up content our audiences love - and that keeps them coming back for more.

SOCIAL MEDIA ENGAGEMENT

Progress Lighting continues to identify and partner with designers across the nation to share inspiration, images and project details online. Through cross-promotional activities, Progress Lighting gives designers a platform to serve as an industry expert and make new connections in the A&D community.

BE INSPIRED

-  @ProgressLtg
-  @ProgressLtg
-  @ProgressLighting
-  @ProgressLtg
-  Progress Lighting
-  Progress-Lighting
-  # ProgressLightingMoments



CURRENT TOOL SALES KIT



CATALOG 133



DESIGN SERIES™

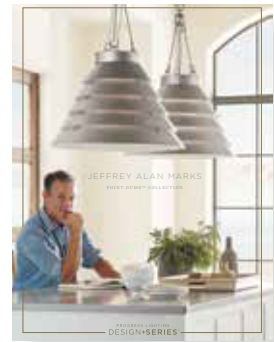

JEFFREY ALAN MARKS BROCHURE

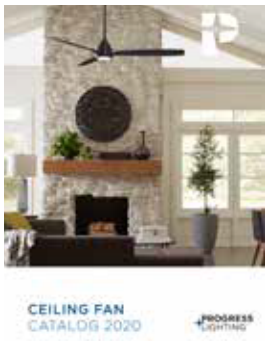

CEILING FAN CATALOG

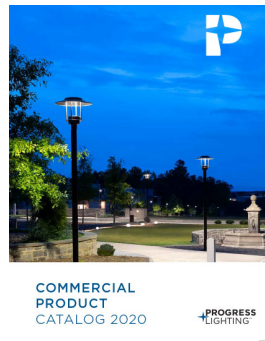

COMMERCIAL CATALOG



CURATED COLLECTION



EXPERIENCE PROGRESS VOLUME 7

RESIDENTIAL LIGHTING GUIDELINES

THE KNOWLEDGE



GENERAL PRINCIPLES

Of all the factors that go into designing a home, lighting may have the greatest power to impact mood, evoke emotion and create drama. Designing with lighting is an art and science in itself. When you're designing for someone else their answers are the right answers to the questions on how they intend to use a space.

CONSIDER WHEN CHOOSING LIGHTING

1. Quantity
2. Color
3. Placement
4. Type of Light



LIGHTING ENVIRONMENT

Lighting can energize or calm – it comes back to a thorough knowledge of what you're trying to accomplish. The first step is decide what type of environment you are trying to create.

BRIGHTER ROOMS

Associate brighter lights with energy, excitement and enthusiasm.

DARKER ROOMS

Lower lights inspire calm, coziness and romance within the home.



HOW TO PROPERLY LIGHT A ROOM

Lighting has the ability to make or break the look and feel of your home. The key to a good lighting plan is a layered approach that combines three types of light: Ambient, task and accent lighting. Certain fixtures lend themselves to each category, and just the right combination can bring your home to life.



Featuring Swing
Image: Toll Brothers

1 AMBIENT LIGHTING

Ambient lighting is the foundational, general illumination that typically comes from an overhead fixture such as a recessed fixture. Multiply the room's square footage by 1.5 to determine the minimum incandescent wattage needed.

2 TASK LIGHTING

Whether reading, cooking, or playing games task lighting helps you perform specific tasks. The rooms where task lighting is imperative are the bathroom and the kitchen, with the use of undercabinet lighting to enhance kitchen safety when using knives, stovetop, etc. For task lighting, multiple the room's square footage by 2.5.

3 ACCENT LIGHTING

Creating visual interest and adding drama to a room is what accent lighting does best. As part of an interior design scheme, it is used to draw the eye to key features such as houseplants, paintings, sculptures and other focal points of a room. Accent lighting requires at least three times as much light on the focal point as the general light surrounding it.

GUIDANCE ON SOURCE CHOICES

It's important to note, not all bulbs are created equal. Choosing the right source for your light fixtures can affect the functionality and appearance of your home, as well as your energy bill. Light output, energy efficiency, durability and style greatly vary from source to source. Consider the following five categories, wattage, lumens, efficacy, temperature and style to choose a lamp that helps you meet design and efficiency goals.

WATTAGE

Before selecting wattage, be sure to look at the maximum wattage your light fixture can yield. Installing the wrong wattage can create excess heat, which can create a serious fire hazard in your home. Wattage indicates the amount of energy a bulb uses (or in other words, how much electric power a bulb consumes), not the amount of light it emits. The chart below helps you choose an energy-saving equivalent to a traditional incandescent source:

Equivalent Light Output

The following wattages are now available for medium base A lamps. It is at our customers discretion to install CFL or LED bulbs. Pay careful attention to the bulb manufacturer's caution statements regarding use in enclosed fixtures or dimmer compatibility.

LEGACY BULBS WATTS (W)	TYPICAL LIGHT OUTPUT (LUMENS)	COMMON CFL LIGHT BULBS WATTS (W)	TYPICAL LED LIGHT BULBS WATTS (W)
40	450	9-13	5
60	800	13-15	9
75	1,100	18-25	13
100	1,600	23-30	17
150	2,600	30-52	22

LUMENS

Lumens measure the amount of light produced by a bulb. Put simply, the more lumens a light bulb has, the brighter the light. For lights that are further from the area they are lighting (such as a recessed can in a 12-foot ceiling) - you will want a higher lumen output to ensure functional illumination. For task applications, higher lumen output is also desired to provide bright, direct light over work areas.

EFFICACY

Efficacy is the measurement of the efficiency of a light source. New packaging makes it easy for consumers to compare efficiency ratings of bulbs. Today, all lamp packages include a Lighting Facts label, required by the U.S. Federal Trade commission, which clearly displays the following measurements:

- Brightness (measured in lumens)
- Energy cost
- Life expectancy
- Light appearance
- Wattage
- Mercury content

EFFICACY TIP ✨

To determine efficacy, divide the lumens by the wattage. For example- 1452 lumens/17 watts = 85 lumens per watt.

TEMPERATURE

The Lighting Facts label is a great resource for determining the warmth of the source. Color Temperature is one of the most important considerations when choosing a bulb.

- Warm light is understood to be up to 3000K (ranges from yellow to reddish)
- Cool light typically is 3600K - 4900K and will have hues from blue to white.

LIGHTING PERFORMANCE	
Light Output (Lumens)	1452
Watts	17
Color Accuracy (CRI)	90
Light Appearance (CCT)	
<p>Warm Cool</p> <p>2700K 3500K 4000K 5000K</p> <p style="text-align: center;">3000K</p>	

STYLE

Finally, it's important to consider the style of your fixture and which type of bulb will further its intended design. For example, a fixture created for exposed bulbs would not be compatible with CFL sources design-wise, due to the spiral shape of the bulb. On the other hand, a light that has a soft, diffusing shade may work really well with a CFL lamp. If your fixture is intended to have an exposed source, selecting a lower lumen output (or mid-century design such as an Edison bulb) might better further the design.



Featuring Durrell

LAMPS

Vintage Lamps



P7825-01
Overall L. 5-7/16" maximum.
40w ST64 Edison E26
medium base. Vintage
Amber bulb.



P7827-01
Overall L. 5-7/16" maximum.
40w T9 E26 medium base.
Vintage Amber bulb.



P7826-01
Overall L. 3-1/2" maximum.
40w T8 E12 candelabra base.
Vintage Amber bulb.

LED Lamps



**VINTAGE LED LAMP
V6.5ST19DLED922/JA8**
6.5w ST19 LED medium base
amber filament lamp
2200K, 450 lumens,
15,000 hours, dimmable.



**LED LAMP
3G9DLED27**
3w LED G9 base lamp
2700K, 270 lumens,
25,000 hours, dimmable.



**LED LAMP
F4T10DLED927/JA8**
4w T10 LED medium base
filament lamp
2700K, 300 lumens,
15,000 hours, dimmable.



EF6.5T10DL9927/JA8
6.5w T10 LED medium
base filament lamp
2700K, 600 lumens,
15,000 hours, dimmable.



F7ST19DLED927/JA8
7w ST19 LED medium base
filament lamp
27000K, 600 lumens,
15,000 hours, dimmable.



**LED LAMP
EF4T8D927/JA8**
4w T8 LED candelabra
base filament lamp
2700K, 300 lumens,
15,000 hours, dimmable.



Landscape Lamps



P7801-01
18w T5 wedge base
clear lamp, 12v.



P7812-01
35w G9 halogen
frosted lamp, 120v.



P7818-01
6-pack of 60w G9 halogen
frosted lamps, 120v.

Krypton Lamps



P7807-01
E12 (candelabra) frost-
ed lamp, 120v.

LAMP REFERENCE CHART

Medium Base - E26



Candelabra Base - E12

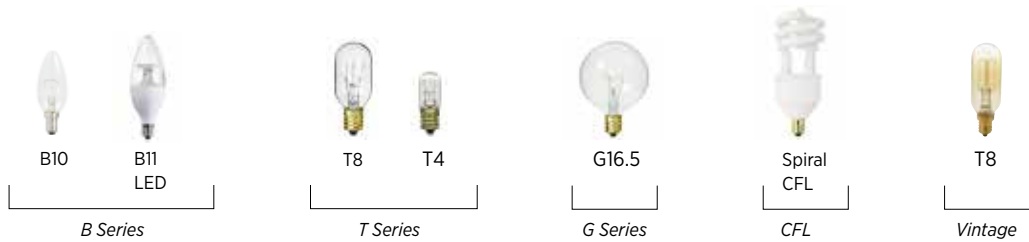

PIN Base

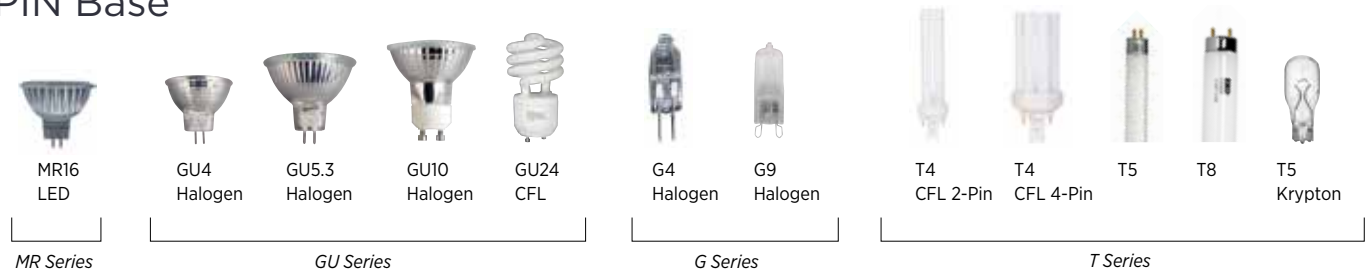

INCORRECT USAGE

DESIGN TIP ✦

If you have a clear, seeded glass or open fixture, use a clear bulb. The white bulb is distracting and takes away from the elegance of the fixture.

RESIDENTIAL LIGHTING GUIDELINES

THE GUIDELINES



Table of Contents

FOYER	14
DINING	16
KITCHEN	18
BATH & VANITY	22
OUTDOOR	24
CREATIVE LIGHTING	26

FOYER

The foyer conveys the first impression of a home's interior. It is often viewed from the outside and makes a transition into the rest of the home.



Featuring Equinox

FOYER SIZING GUIDELINES

Foyers

The rule of thumb is to accommodate 2.5 - 3 inches of chandelier height for each foot of ceiling height.

9' - 10' Ceiling

Hang a fixture using a guideline 7-to-7.5 feet should proceed sufficient results.

11' + Ceiling

Divide the vertical space into thirds, positioning the fixture(s) two-thirds of the distance from the floor, so that the ceiling height does not overwhelm the space. If the foyer is large and has a high ceiling, it's recommended to choose a slightly larger fixture than formulas suggest.

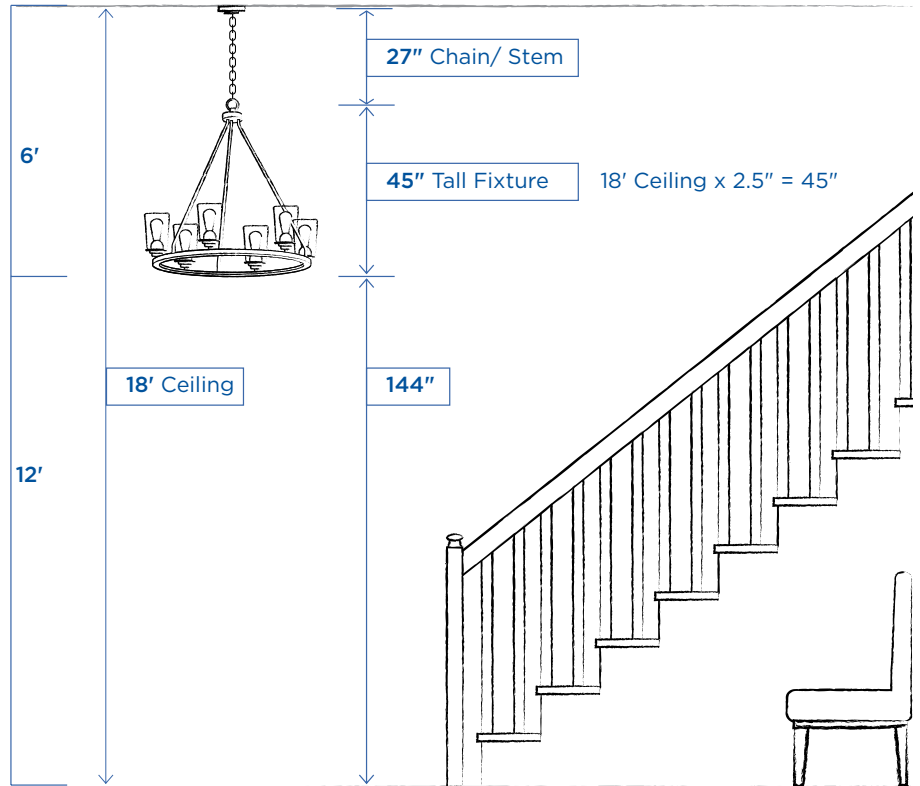

Foyer Sizing Recommendations

**Note: confirm that light doesn't interfere with door swing. If it does, place it further back.*

ROOM WIDTH (smallest rm. dimension)	Fixture Width			ROOM HEIGHT	Fixture Height	
	Max.	Target	Min.		Max.	Min.
5'	21"	16.8"	9"	8'	12"	-
6'	25.2"	20.2"	10.8"	9'	24"	-
7'	29.4"	23.5"	12.6"	10'	30"	18"
8'	33.6"	26.9"	14.4"	11'	33"	19.8"
9'	37.8"	30.2"	16.2"	12'	36"	21.6"
10'	42"	33.6"	18"	13'	39"	23.4"
11'	46.2"	37"	19.8"	14'	42"	25.2"
12'	50.4"	40.3"	21.6"	15'	45"	27"
13'	54.6"	43.7"	23.4"	16'	48"	28.8"
14'	58.8"	47"	25.2"	17'	51"	30.6"
15'	63"	50.4"	27"	18'	54"	32.4"
16'	63"	53.8"	28.8"	19'	57"	34.2"
17'	71.4"	57.1"	30.6"	20'	60"	36"
18'	75.6"	60.5"	32.4"	21'	63"	37.8"
				22'	66"	39.6"
				23'	69"	41.4"
				24'	72"	43.2"

DINING

Whether you use your dining room for everyday meals or special occasions, lighting will always be key for this multi-purpose room. Lighting in the dining room focuses on the table.



Featuring Blakely
Image: Cornerstone Homes

DINING SIZING GUIDELINES

Dining

The table under the fixture should serve as a guide for selecting the right fixture for your space. To calculate the correct width, start with the width of your table and subtract 12". (For example, if your table is 42" wide, your chandelier should not be more than 30" wide.)

Based on an 8' ceiling, your fixture should hang between 30"-36" above the table.

*Minimum Width Recommendations:
Add width of room + length and use this number as inches*

Note: For 10'-0" ceiling heights or below, fixture should not exceed width of table less than 12".

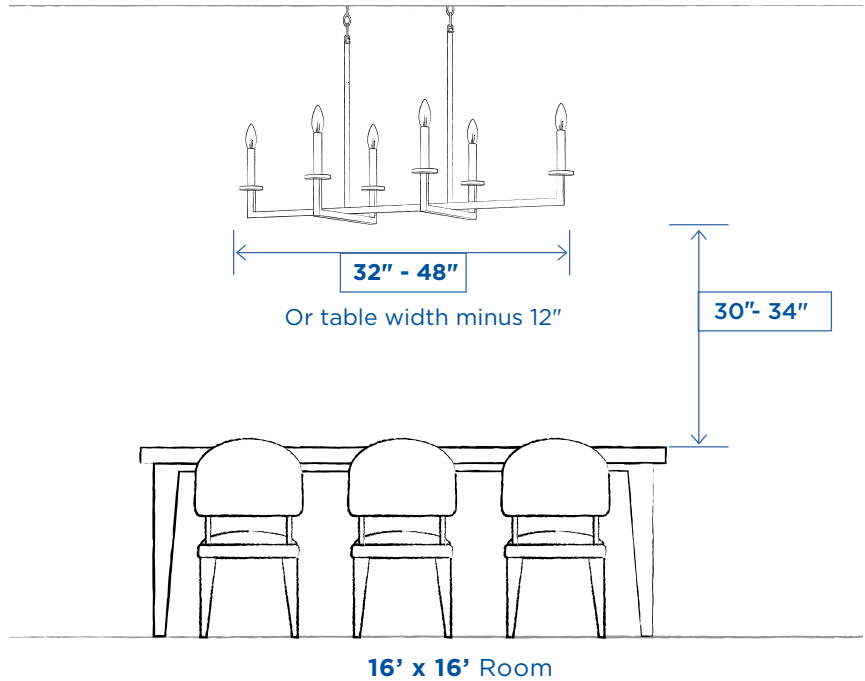

Dining Sizing Recommendations

ROOM WIDTH (smallest rm. dimension)	Fixture Width	
	Max.	Min.
10'	30"	See Notes Above in Drawing
11'	33"	
12'	36"	
13'	39"	
14'	42"	
15'	45"	
16'	48"	
17'	51"	
18'	54"	
20'	57"	
21'	63"	

ROOM HEIGHT	Fixture Height
	Max.
8'	24"
9'	27"
10'	30"
11'	33"
12'	36"
13'	39"
14'	42"
15'	45"
16'	48"
17'	51"
18'	54"

Dining Mounting Recommendations

Ceiling Height	Distance from bottom of fixture to table surface
8'	30"
9'	33"
10'	36"
11'	39"
12'	42"
Above 12'	Fixture should be mounted more in relation to the room than to the table

KITCHEN

The kitchen is often the busiest room in the house. Not only is food prepared here, but many activities such as eating, entertaining, homework, reading and relaxing are performed.



Featuring Surfrider
Image: KHOV

KITCHEN SIZING GUIDELINES

Kitchen Pendants

Start the row 12"-15" in from either end of the island and then space the pendants evenly within that span.

Space pendants around 24"- 30" apart from one another (depending on style & quantity).

Pendants should be at least 10" smaller in diameter than the width of the countertops. Consider the rule of odd numbers (unless using oversized fixtures).

Keep 30"-36" of space between the countertop and fixtures.

- 8' island = 96"
- $96'' - 24''$ (12" from ends of island) = 72"
- $72'' - 24'' - 24'' = 24''/3 = 8''$ diameter max. (spaced 24" apart from each other)
- $72'' - 30'' - 30'' = 30''/3 = 4''$ diameter min. (spaced 30" apart from each other)

Kitchen Recessed

Keep 30" away from the wall and space evenly for 4" recessed space 4' apart but for 5" space 5'.

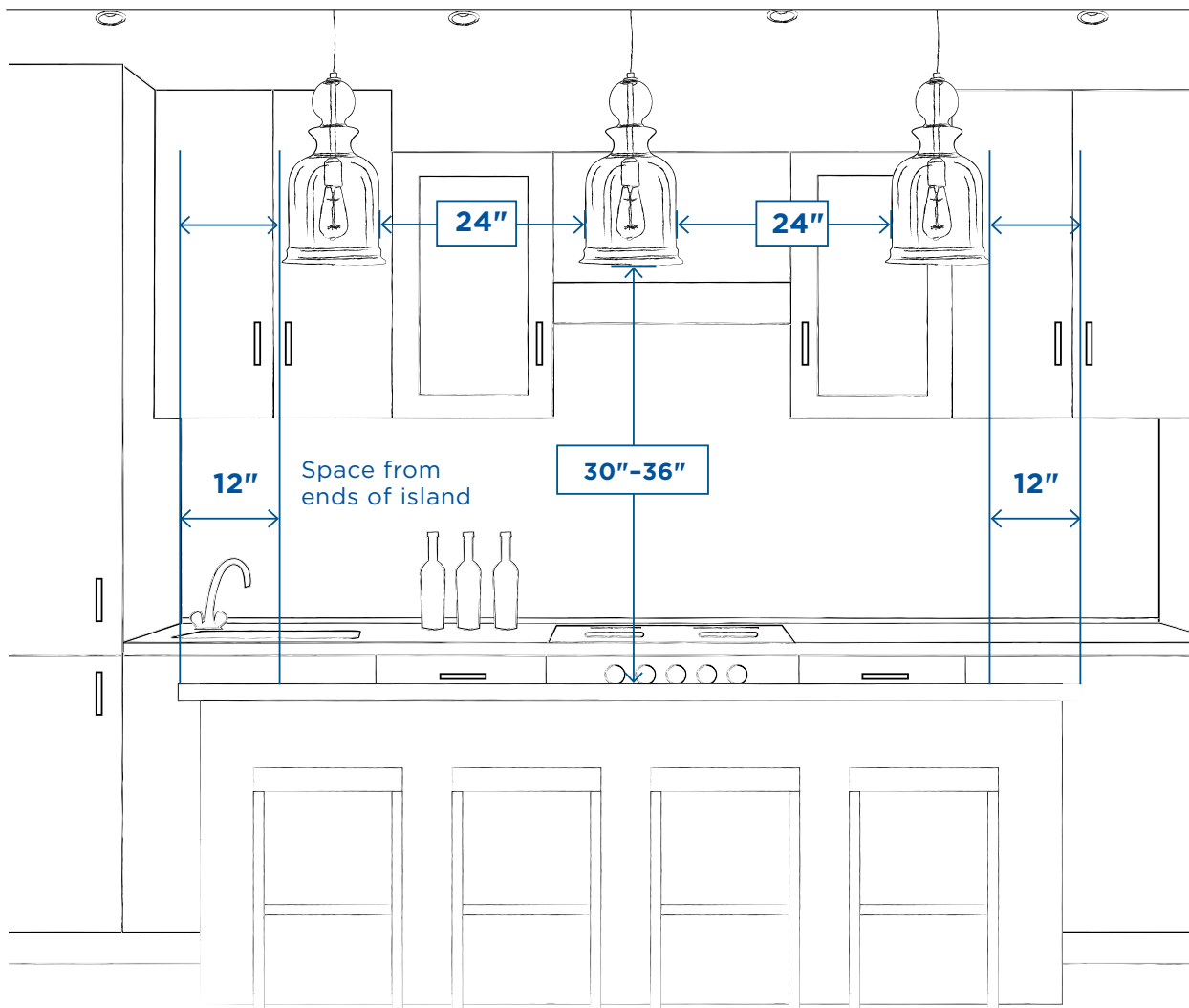

Featuring Staunton, Tape and Linear Undercabinet
Image: Beazer Homes

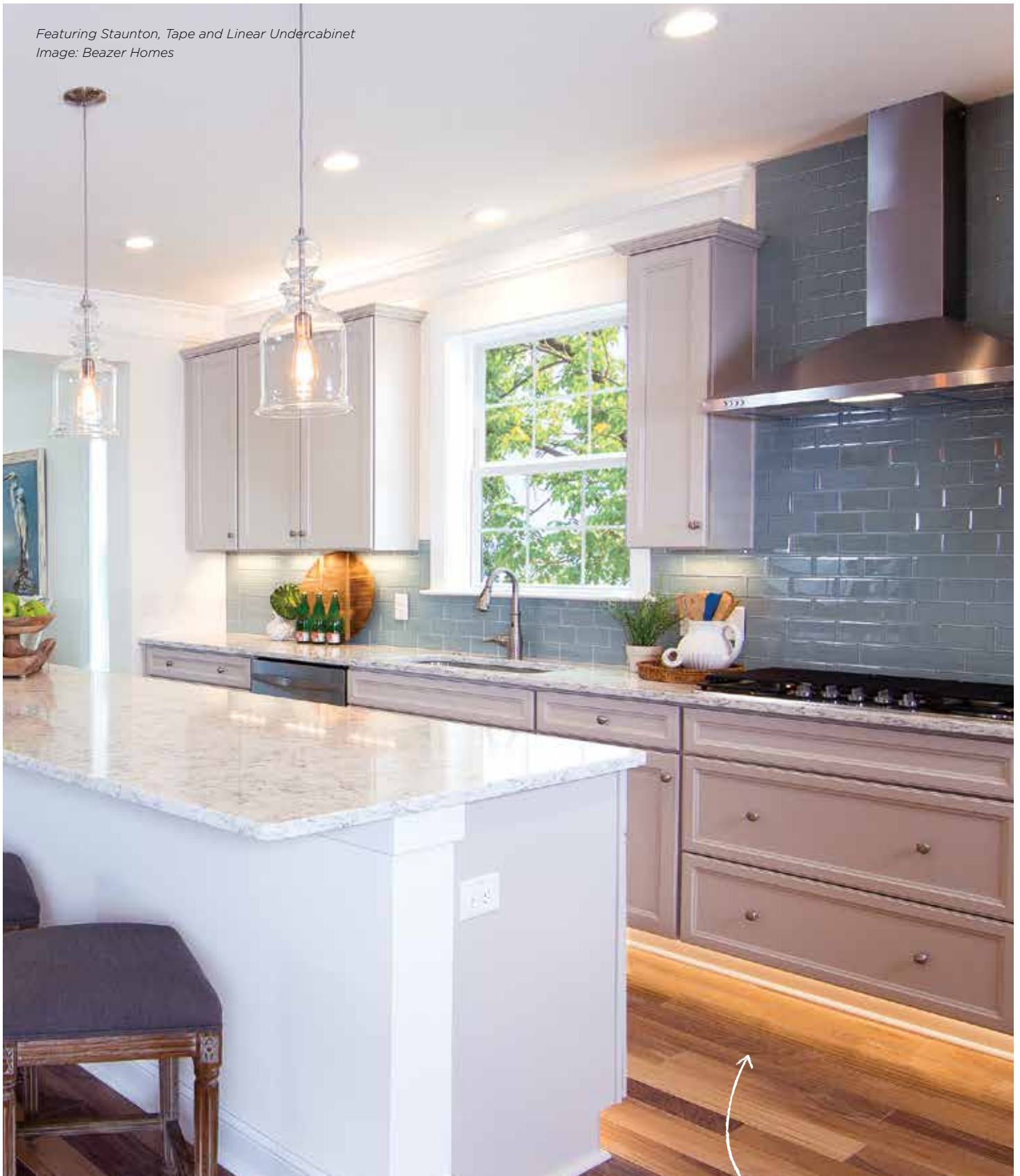

LIGHTING DESIGN TIP ✦

The use of Hide-a-Lite fixtures in cabinets, valances and toe kick spaces creates drama, while creating light to safely navigate through the kitchen late in the evening.



Puck lighting is used to create focused lighting effects that highlight decorative elements. Puck can be used inside and underneath cabinets when a spot or targeted light distribution is desired.

Puck Lights

Pick linear undercabinet lighting where even illumination and high light levels are desired. It comes complete with 120V direct wire application, eliminating the need for remote power supplies or conversion boxes, and an on-off switch for easy access task lighting.



Linear Undercabinet



Tape Lights

LED tape lights are most often sold on a roll in various lengths. The strip can be cut to fit a specific size. Choose tape lighting where space is limited. Its long, continuous length, low profile, flexibility for navigating curves, and adhesive backing that sticks to many surfaces makes it perfect for areas such as toe kicks and cove lighting, where the length of the tape can be longer than the cabinetry if needed.

BATH & VANITY

The key task lighting in bath areas is at the mirror to provide shadow-free lighting on the face.



Featuring Penn
Image: Daniella Benloulou

BATH & VANITY SIZING GUIDELINES

Single Bowl Vanities

Position fixtures on both sides of the mirror is the best way to provide shadow-free lighting for your face. The ideal width is at least 28 inches apart, and centered at 70-80" inches above the floor. If you choose to place your lights above the mirror, the width of your fixture should be at least 1/3 the width of the vanity mirror, but should never exceed its total width.

Task Lighting

Center recessed downlights 24" to 36" between where the face and the mirror are at the vanity to eliminate shadows.

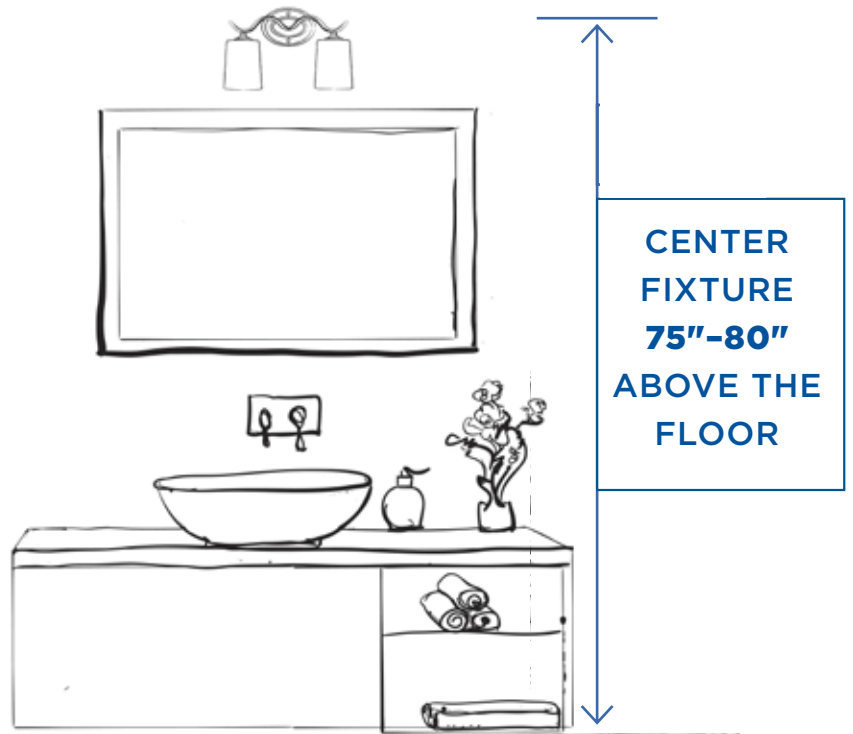
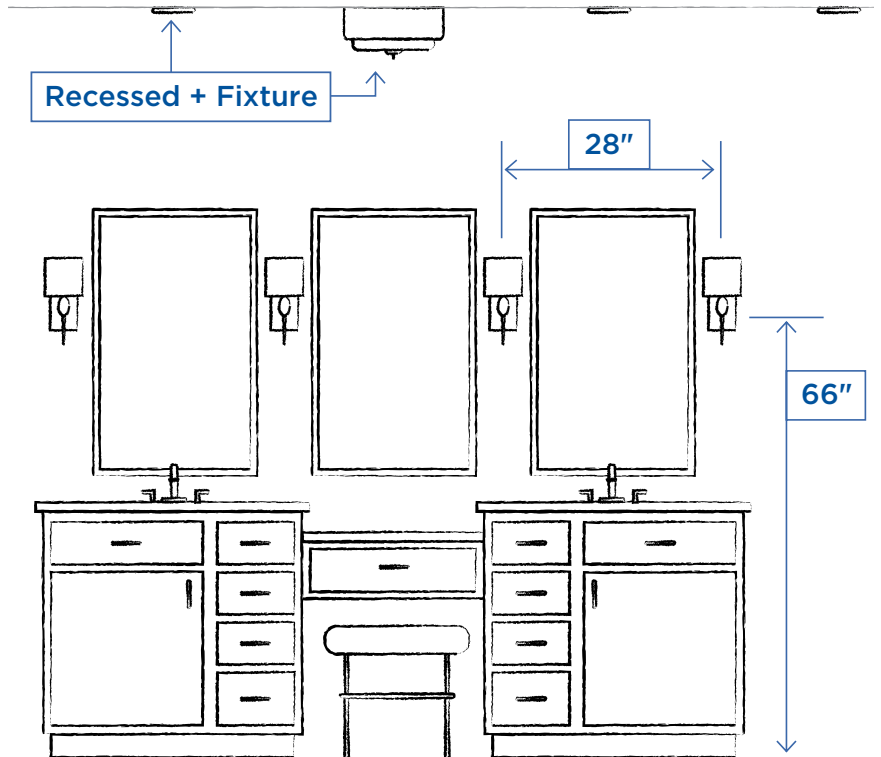



Featuring Glayse
Image: Schumacher Homes / Possibilities for Design

BATH & VANITY SIZING GUIDELINES

Vanities With Two Sinks

In bathrooms with two sinks, another great option is to mount two separate fixtures, one above each sink.

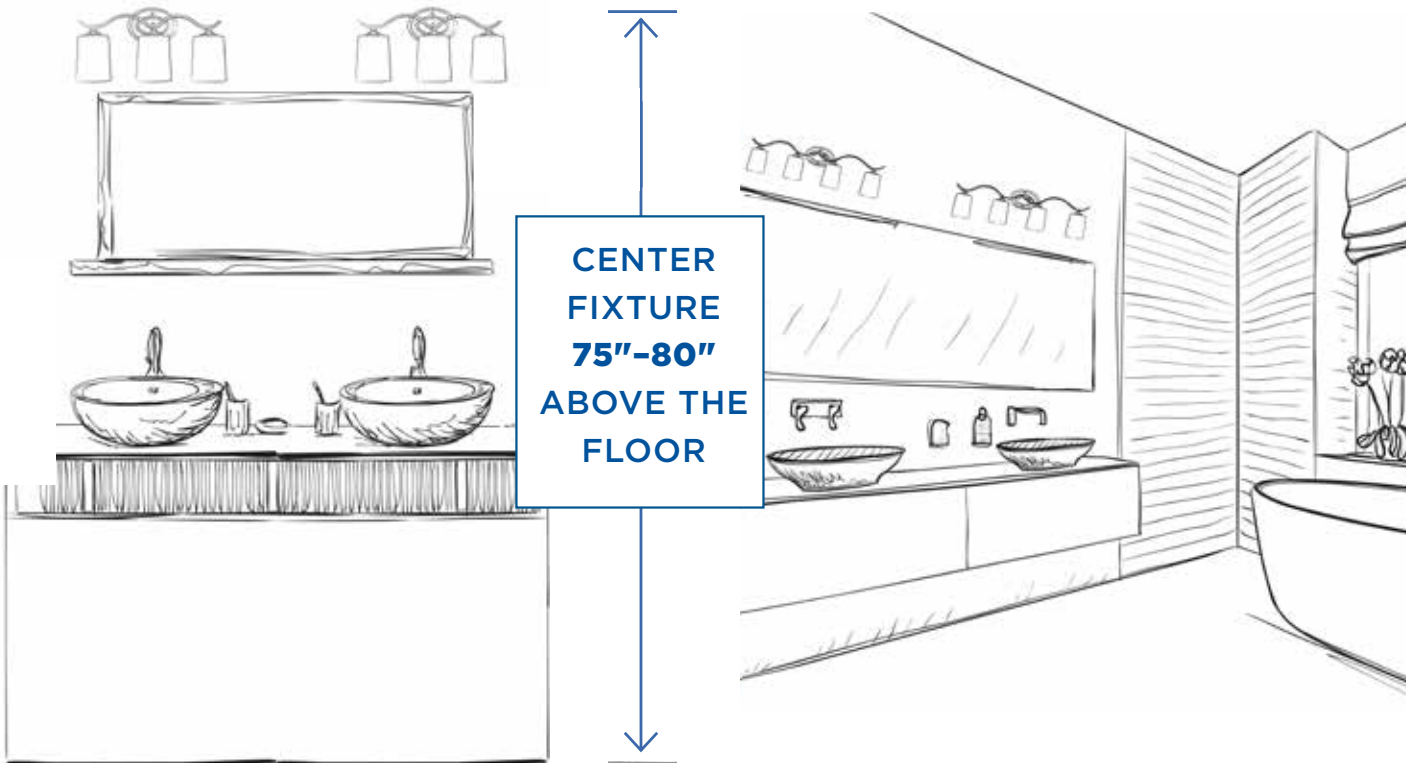

LIGHTING DESIGN TIP ✦

Today, bathrooms are all about creating a space to unwind and relax. Give this everyday area a luxurious appeal by adding a chandelier. Bathroom design tip: Consult an electrician in your area before installing a fixture above the tub to ensure it complies with building codes.

OUTDOOR

Outdoor lighting is essential to enhancing the beauty of your home, while adding security. Extend the day with proper outdoor lighting.



Featuring Galveston

OUTDOOR SIZING GUIDELINES

Front Door – Wall Lanterns

For a front door with two lanterns, the lantern height should be approximately 1/4 the height of the door. Front doors with one lantern should be approximately 1/3 the height of the door. Mount lanterns approximately 66" above floor for accurate lighting effects.

For a door that is 96" in height, multiply the height by .25 to get 24" for the suggested height of each fixture.

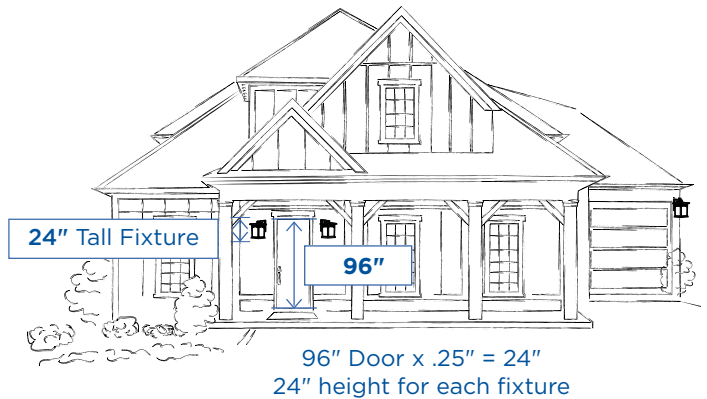

Front Door – Hanging Lanterns

For a front door with a hanging lantern, the lantern height should be approximately 1/5 the height of the door.

Hanging lanterns are hung using chain or stems connections, so be sure to consider the additional length of the chain or stem. The hanging lantern should not hang below 7' from the ground, including the fixture, chain and stem.

Allow 6" minimum clearance from the bottom of the lantern to the top of the door to allow the door to open and close. If there is not enough clearance, consider using a flush mount outdoor fixture. the height of the door.

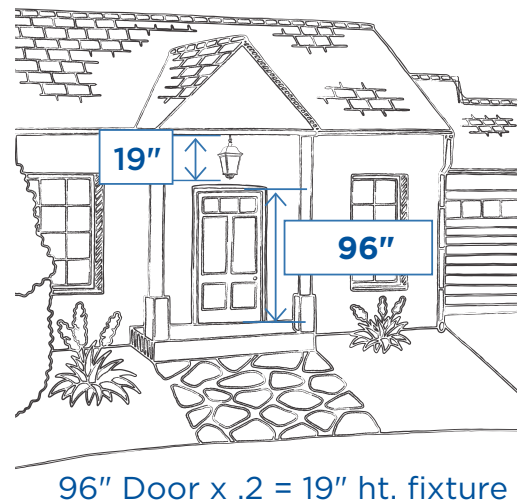

Garage – Wall Lanterns

If you are installing two or more wall lanterns on the exterior of your garage, the lantern height should be approximately 1/4 the height of the door. For installing a single wall lantern, the height of the fixture should be approximately 1/3 the height of the door.

For a garage door that is 16' in height, multiply the height by .25 to get 4'. Divide 4' by 2 to get 2', which is the suggested height of each fixture.

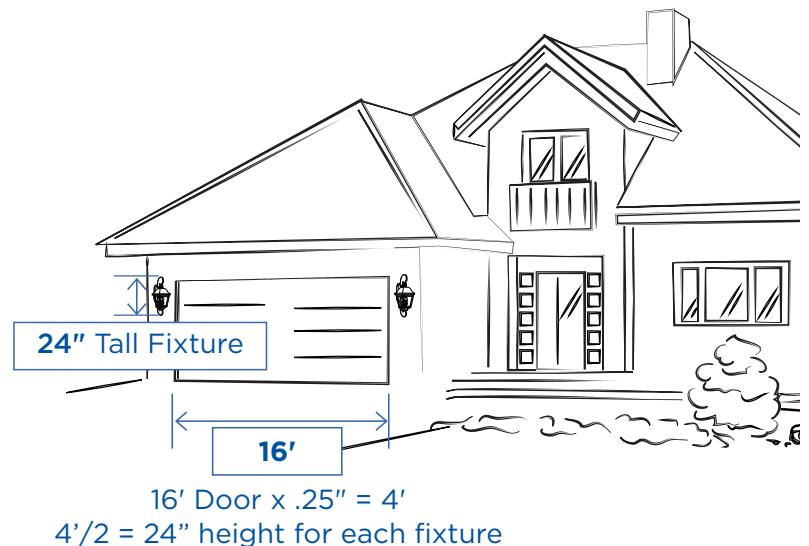

CREATIVE LIGHTING

Be creative with your lighting.
Combine different kinds of lights
or group many of the same
lights to make a big impact.



Featuring Staunton



Featuring Rainey

Hang Fixtures In Multiples



Featuring Lookout



Featuring Pivot



LIGHTING DESIGN TIP ✦

Use a canopy as a great tool and creative way to hang multiple fixtures at once.



Toss Your Table Lamp



Bring the Outdoors Inside

EQUIP. EDUCATE. EXCITE.

These three words define the mission of Progress Lighting. Flip through our residential lighting guidelines, and you'll quickly see how we equip you with the education to make all your exciting design dreams come true. Whether you're looking for the latest and greatest trends or some tried-and-true pieces, you'll find the just-right lighting choices to illuminate the special moments in your life. Not sure where to start? Whether you're browsing our catalog or visiting our website, Progress is at your service to help you envision where and how to use our products.

TO FIND YOUR STYLE,
TAKE THE QUIZ.
www.progresslighting.com/styles



EXPERIENCE PROGRESS

Learn how lighting can totally transform a space. Experience Progress features beautiful room images from our builder partners, design firms, social media fans and influencers bringing the Progress Lighting story to life. By working together, we're furthering a vision of providing whole home solutions to those who are seeking inspiration.







Visit www.progresslighting.com/experienceprogress.

OUR BLOG

Explore our blog for even more design inspiration, product integration and trend guidance to make your home into a haven of livable luxury.

See www.progresslighting.com/blog.

BE INSPIRED

-  @ProgressLtg
-  @ProgressLtg
-  @ProgressLighting
-  @ProgressLtg
-  Progress Lighting
-  Progress-Lighting
-  # ProgressLightingMoments



701 Millennium Boulevard
Greenville, SC 29607
www.progresslighting.com

